

STÛV 21:

SPECIFICATIONS & MANUFACTURER INSTALLATION GUIDE

stûv

LE FEU ESSENTIEL

1. PRELIMINARY INSTALL INFORMATIONS

In relation to the installation and use of this appliance, the installer and the user should strictly adhere to local and national regulations as well as Australian & New Zealand Standards AS/NZS 2918:2001. They should also follow the instructions detailed in the Stuv 21 installation and user manual. Safe operation of the fireplace is directly dependent thereon. The liability of the manufacturer can neither be retained nor assured following failure of installation or incorrect use which is not compliant with AS/NZS 2918:2001.

As each installation is different, a qualified and licensed trades professional should take all required preliminary precautions depending on the technical elements inherent to each job.

In-observance of the assembly instructions in conjunction with AS/NZS 2918:2001 entails the liability of the person who carries it out.

Fireplace structure and finishes shall be to your own design providing the exact and minimum dimensions are maintained.

The floor must have adequate strength to support the fireplace. N.B. Timber floors may require additional reinforcing.

Construction of the fireplace structure from floor to ceiling shall be: solid brick (110mm minimum), Silicate board (40mm), stone (100mm minimum) or Hebel aerated blocks (150mm minimum).

When installed on a combustible floor surface the Stuv 21 firebox must be positioned on top of a 18mm cement sheet floor plate and raised to a minimum height of 150mm using the appliance adjustable feet.

As a result of faulty assembly, use of parts or additional components not supplied by the manufacturer/distributor, and/or modifying of the appliance or components will result in inferior or unsafe operation. Should this occur the manufacturer/distributor bears no liability, and will result in a null and void product warranty.



2. SPECIFICATIONS

SINGLE FRONTED MODEL - STUV 21

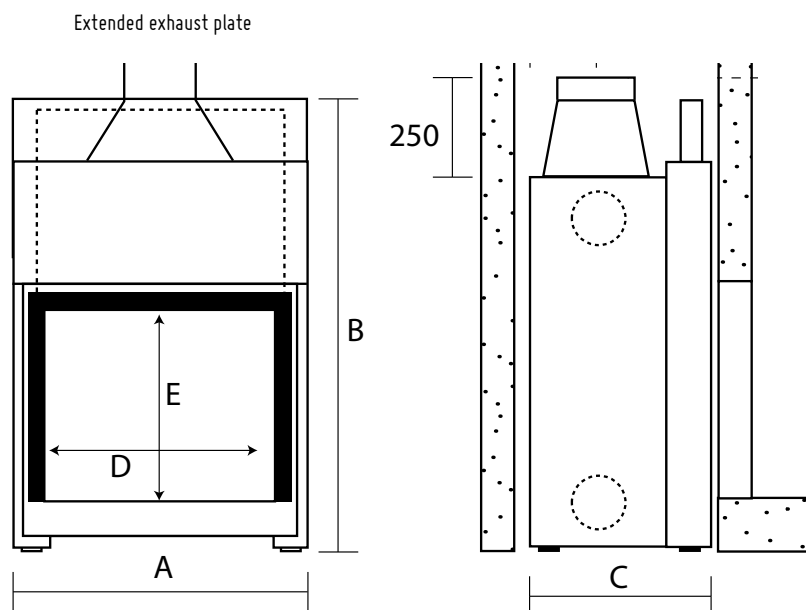

DIMENSIONS (mm)

	STUV 21 / 95 SF	STUV 21 / 105 SF	STUV 21 / 125 SF	STUV 21 / 135 SF
A	950	1050	1250	1350
B	1455	1040	1295	1040
C	590	496	563	500
D	770	870	1070	1170
E	615	400	535	400

OTHER DETAILS

	STUV 21 / 95 SF	STUV 21 / 105 SF	STUV 21 / 125 SF	STUV 21 / 135 SF
OUTPUT KW	10kw to 18kw	7kw to 19kw	11kw to 23kw	11kw to 21kw
HEATING CAPACITY	120m ²	125m ²	145m ²	130m ²
MINIMUM FLUE HEIGHT	4.5m	4.5m	4.5m	4.5m
WEIGHT (excluding zero clearance casing)	292kg	224kg	305kg	286kg
MAX LOG SIZE	60cm	80cm	100cm	100cm
ACTIVE FLUE SIZE	10"	8"	10"	10"

2. SPECIFICATIONS

DOUBLE FRONTED MODEL - STUV 21

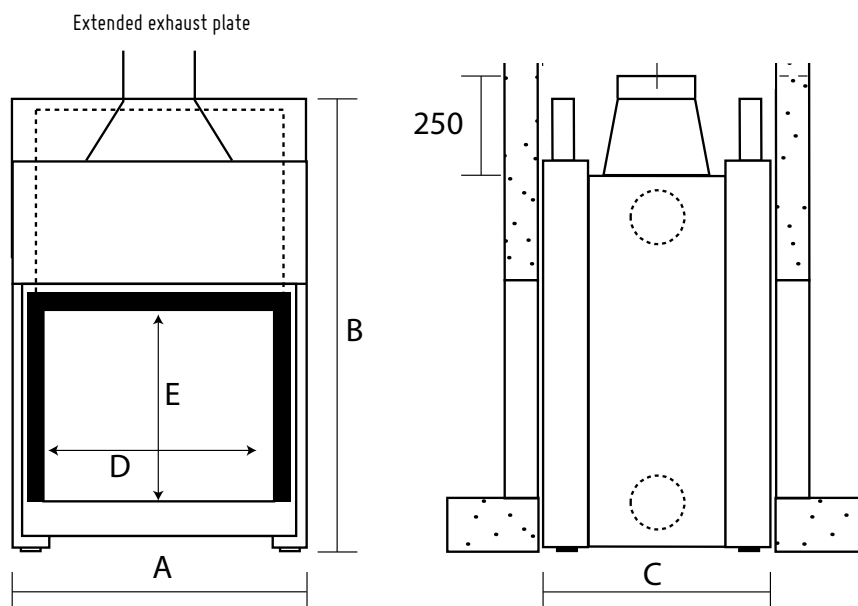

DIMENSIONS (mm)

	STUV 21 / 95 DF	STUV 21 / 125 DF
A	950	1250
B	1455	1295
C	670	670
D	770	1070
E	615	535

OTHER DETAILS

	STUV 21 / 95 DF	STUV 21 / 125 DF
OUTPUT KW	12kw to 27kw	14kw to 27kw
HEATING CAPACITY	165m ²	165m ²
MINIMUM FLUE HEIGHT	4.5m	4.5m
WEIGHT (excluding zero clearance casing)	297kg	310kg
MAX LOG SIZE	70cm	100cm
ACTIVE FLUE SIZE	10"	12"

3. CLEARANCES - IMPORTANT

When installed on a combustible floor surface the Stuv 21 firebox must be positioned on top of a 18mm cement sheet floor plate and raised to a minimum height of 150mm using the appliance adjustable feet.

When installed on a non combustible floor the fireplace can be installed directly onto the floor and adjusted in height using the adjustable feet.

In a cavity built out of bricks the appliance must be installed with a minimum gap of 50mm at the back and on the sides.

In a cavity built out of silicate boards the appliance must be installed with a minimum gap of 100mm at the back and on the sides.

Only non-combustible material (silicate board, cement sheet or brickwork) shall be used on the front wall of the cavity.

All internal framework above the appliance shall be made of non-combustible material.

The cavity above the appliance must be capped and must have a minimum of 2500cm² of venting.

The appliance must be fitted with the a standard triple skin flue.

To conform with the requirement of the joint AS/NZS 2918:2001 the appliance must be fitted with a minimum two heat transfer ducts and two room air inlet ducts.

4. INSTALLATION - FLOOR PREPARATION

NON-COMBUSTIBLE SURFACE

The Stuv 21 can be installed straight onto the surface with no prior preparation required.

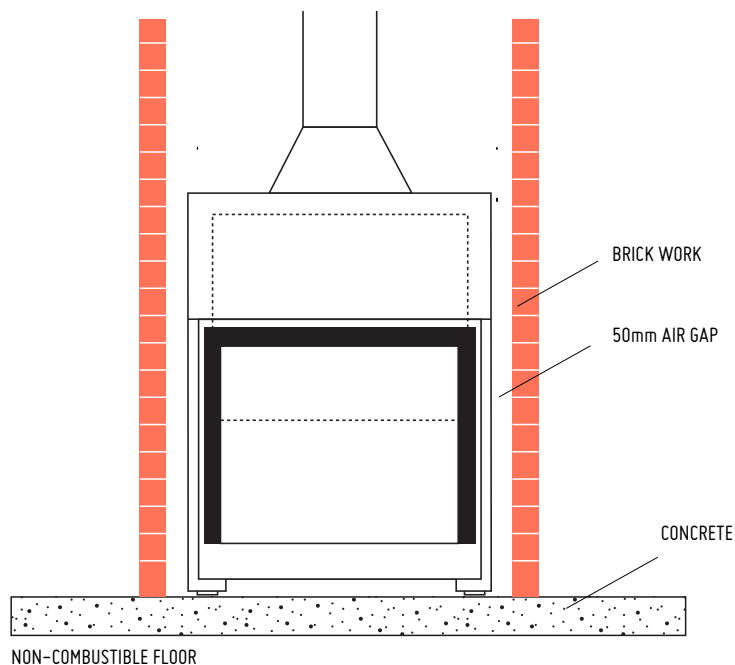

COMBUSTIBLE SURFACE

The Stuv 21 must be installed on a 18mm tick cement sheet plate (minimum) and raised using the appliance's adjustable feet so that the bottom edge of the firebox door is at least 300mm from the floor.

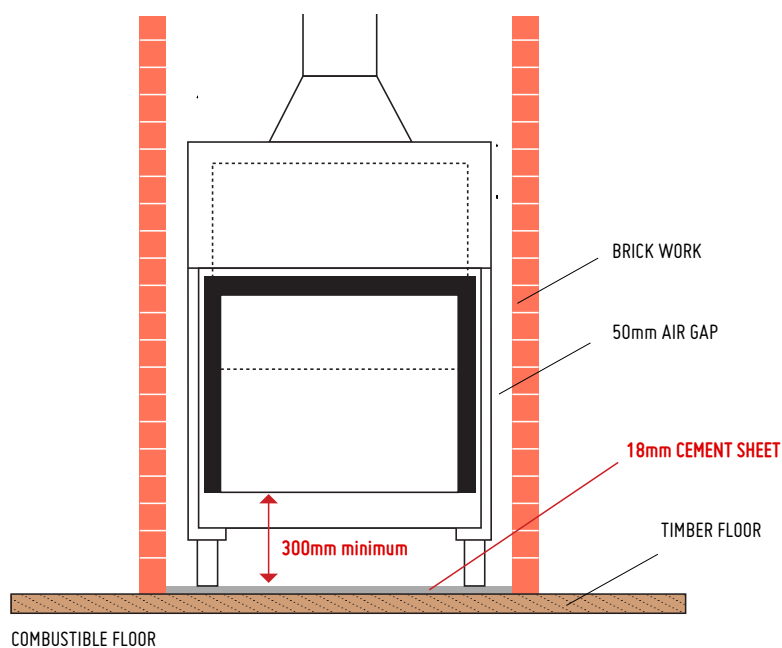

4. INSTALLATION - WALL CAVITY (USING SILICATE BOARD)

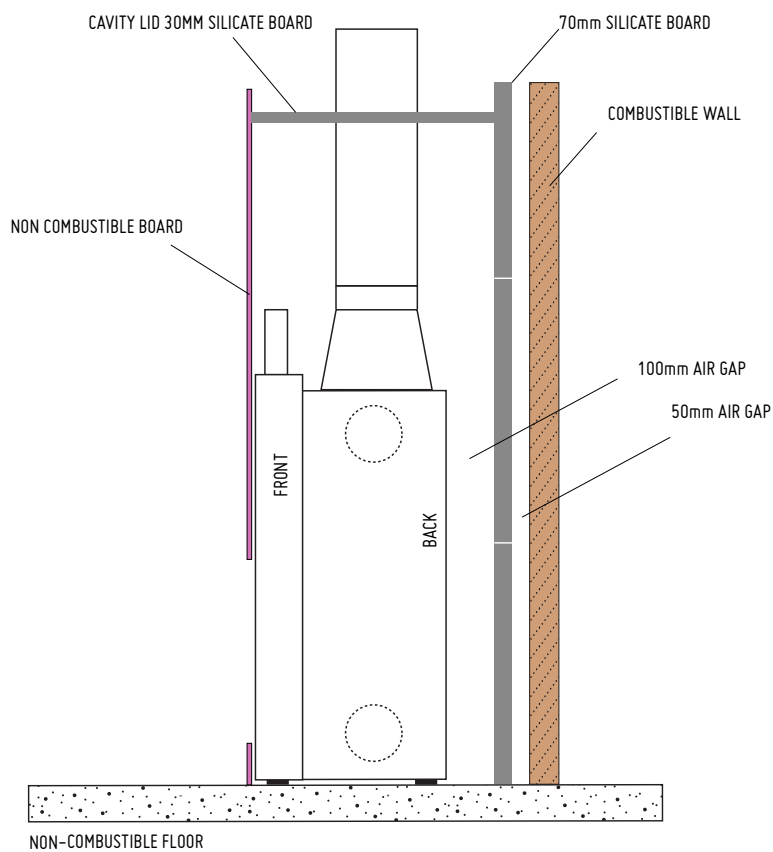
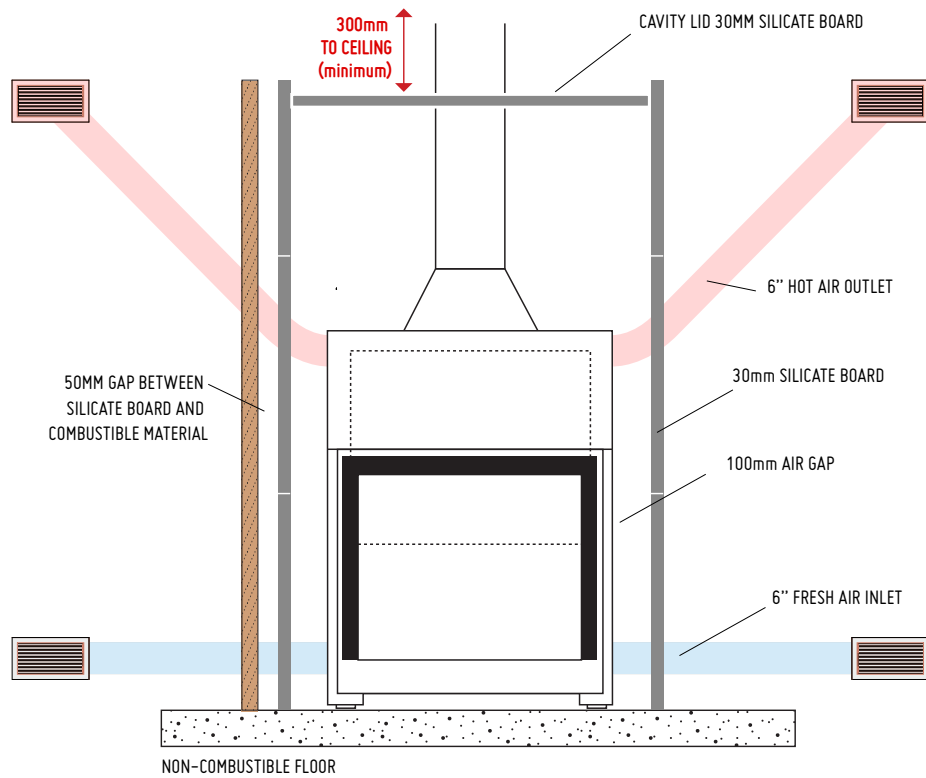

4. INSTALLATION - WALL CAVITY (USING BRICKWORK)

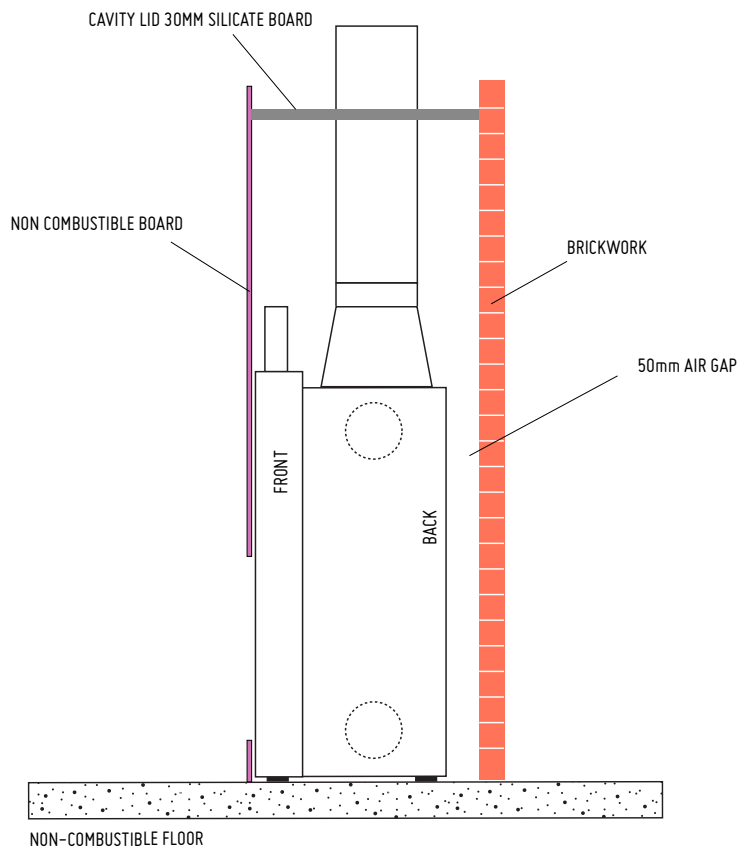
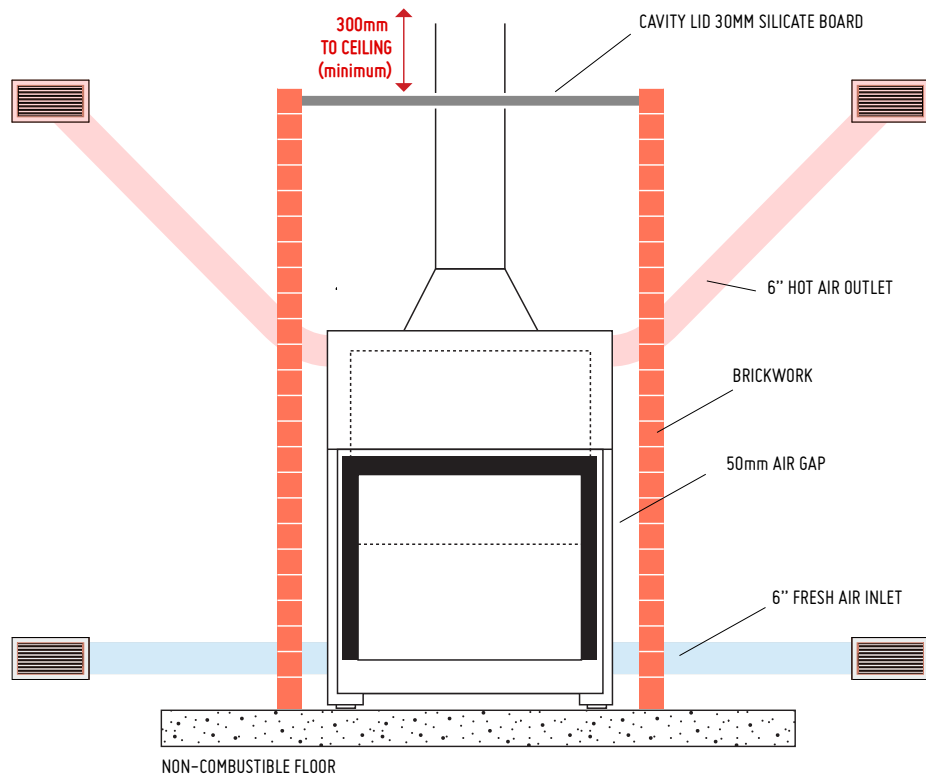

4. INSTALLATION - HEARTH

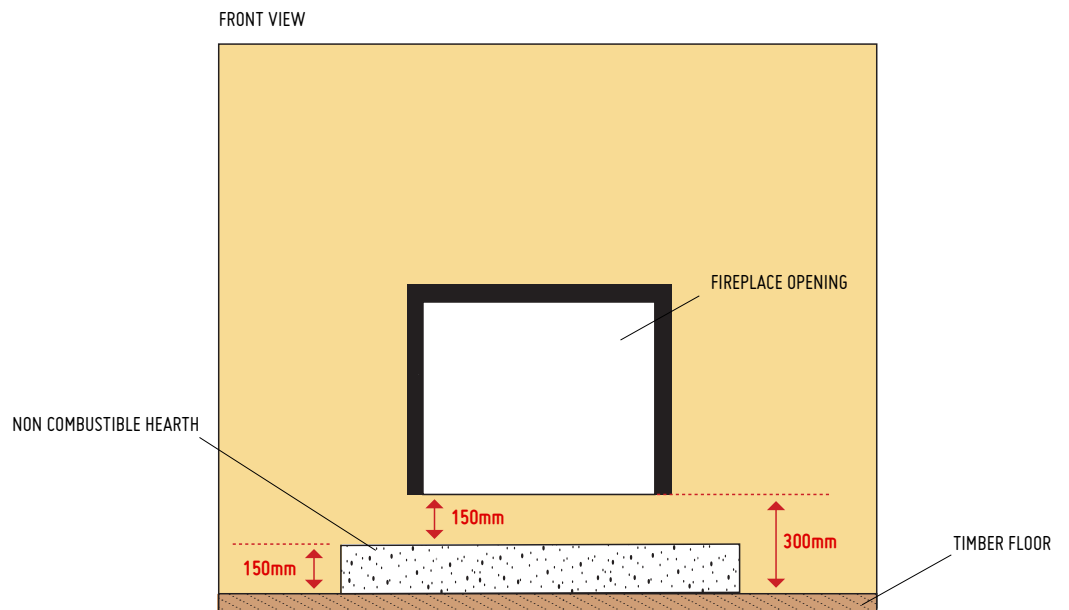

For installations where a combustible floor is situated in front of the Stuv 21 a non combustibe hearth (floor protector) is required.

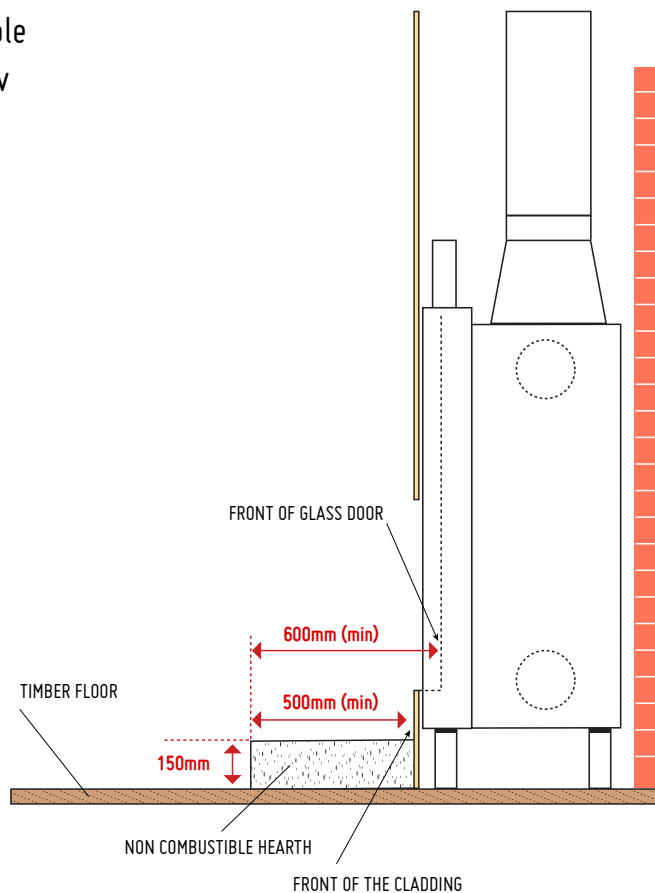

4. INSTALLATION - FLUE

The minimum flue run for all Stuv fireplaces must be 4.5m from the appliance to the top of the external flue.

Coming off of the appliance the flue must run straight vertically for a minimum of 900mm before a bend or elbow can be included in the flue run. Elbows or bends in the flue must be a maximum angle of 45°

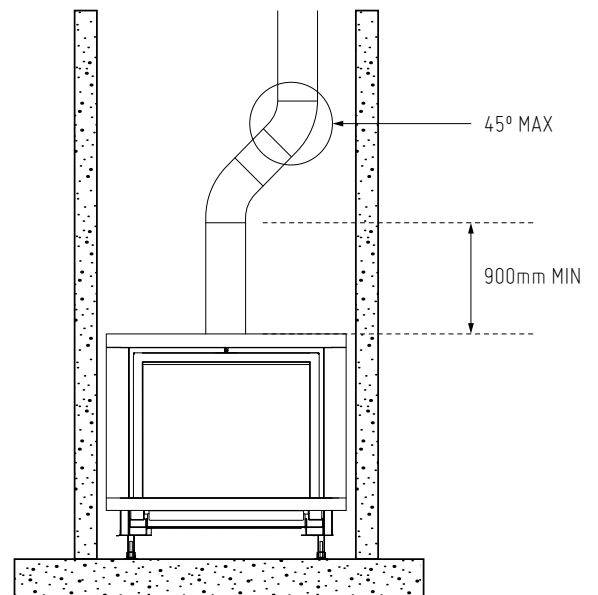
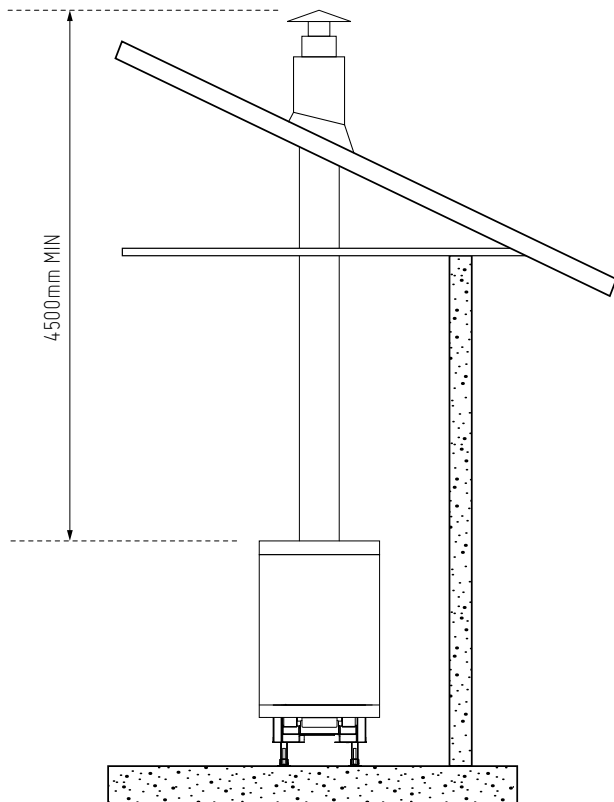

4. INSTALLATION - SHELVES

COMBUSTIBLE SHELF

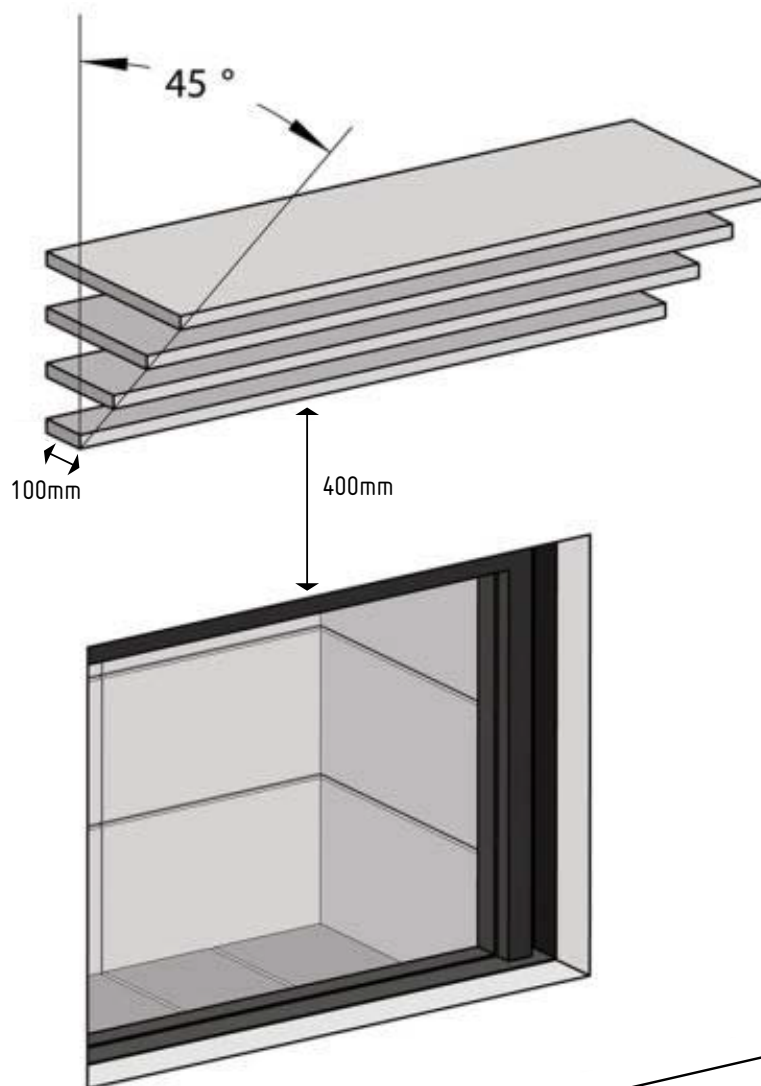

5. CONVECTION

Convection air inlets are through single wall flexible ducts.

Convection air outlets must be through insulated double wall ducts.

It is important that the air flow is continuous. It is therefore forbidden to remove the air from a room and send it to another airtight room.

Use a minimum of 2 fresh air inlets and 2 hot air outlets.

The distance between the ceiling and the center of the hot convection grill must be at least 35cm.

The horizontal distance between the hot air convection grill and the appliance cannot be greater than 3m.

The vertical distance between the hot air convection grill and the appliance is not limited.

See fig I and J.

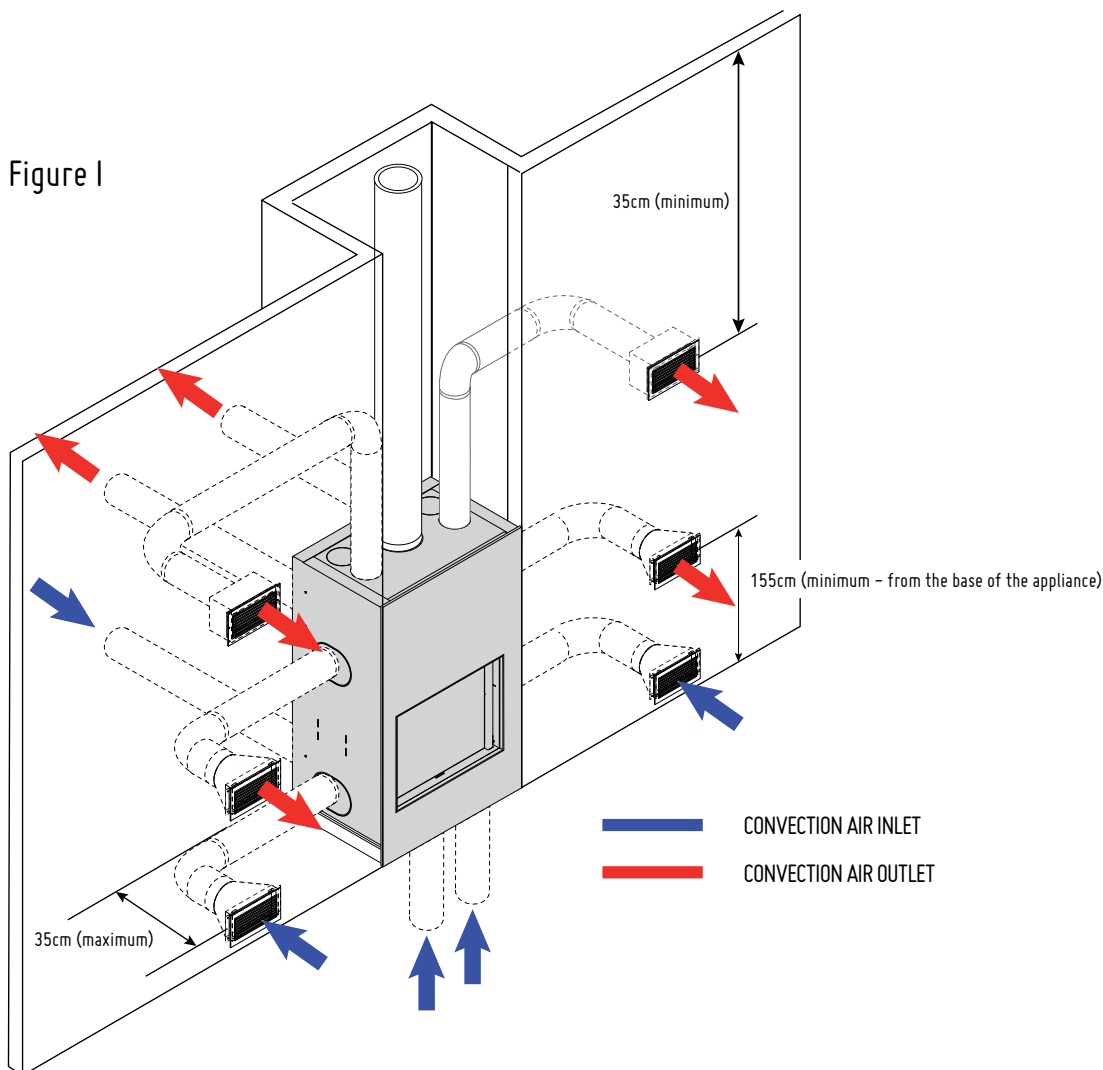

5. CONVECTION

HOT AIR OUTLETS

Figure J

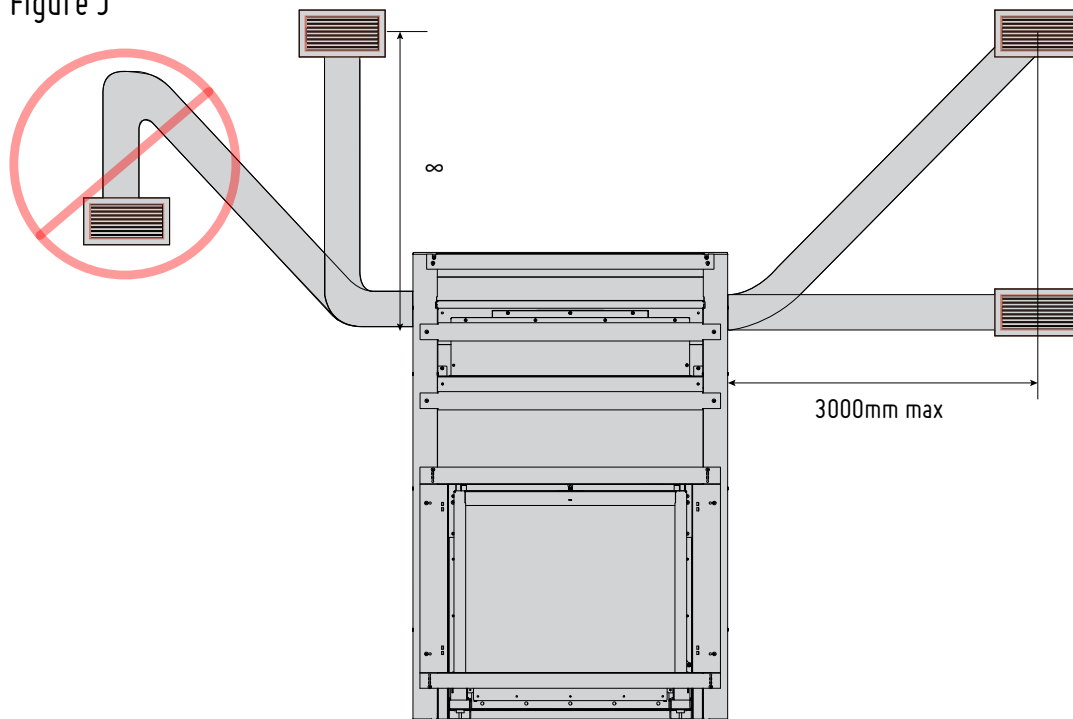

CONVECTION AIR CIRCULATION

The convection air never comes into contact with the fire. The convection is an independent air channel. The air circulates around the combustion chamber, gets hot and goes out through convection grates in the same room or in other rooms.

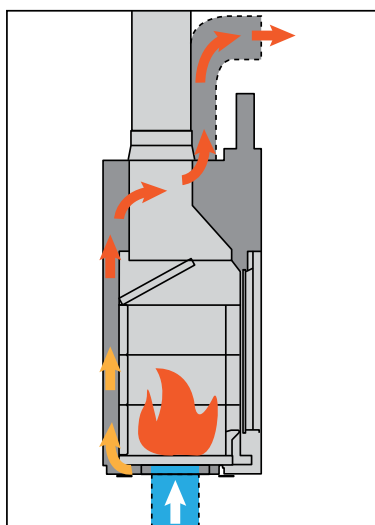

CONVECTION AIR CIRCULATION

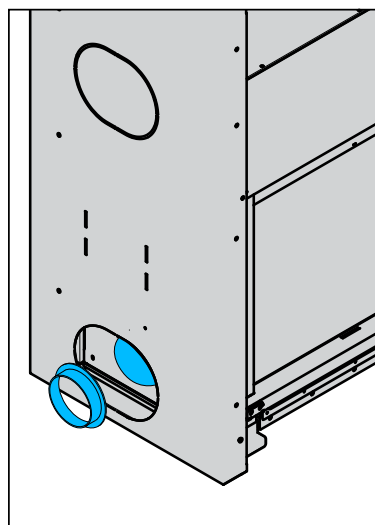

CONVECTION AIR INLET

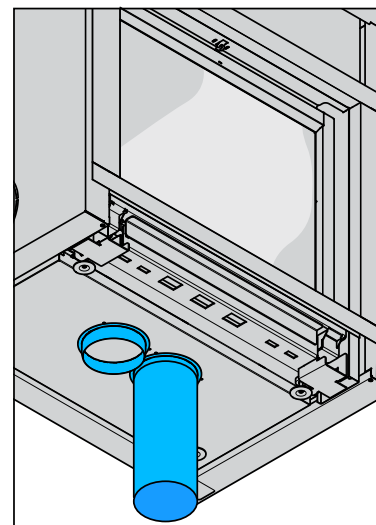

CONVECTION AIR INLET

6. COMBUSTION

When operating with an open fire, the Stuv 21 consumes a large amount of air. Therefore, we recommend providing an external air supply, although this is not mandatory.

A sufficient air inlet must be created under the stove, at the front. When not using the air intake box with connected duct, the base of the fire must be supplied with fresh air. The fresh air must come from a ventilated empty space, a ventilated room or from outside the house (mandatory for passive/air tight buildings). **ONLY DUCT THE FRESH AIR INLET TO THE APPLIANCE USING THE INTAKE BOX.**

The air intake, which varies depending on the model, should ideally be located beneath the front of the unit and incorporate a shut-off register (fig a).

Ideally the fresh air inlet would be fitted with a closure valve (fig e and f) to prevent the room from becoming cold when the appliance is not in use. It should ideally be located as close as possible to the outside wall and controlled from inside the room.

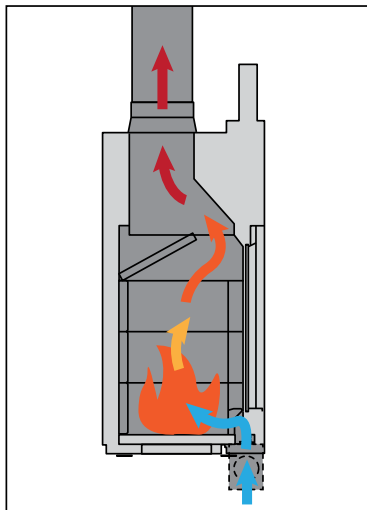

a. COMBUSTION AIR CIRCULATION

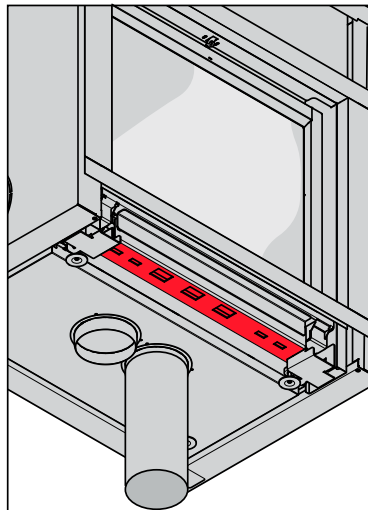

b. COMBUSTION AIR INLET

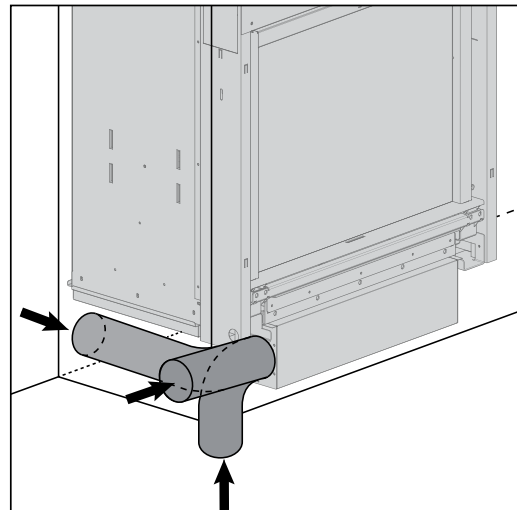

c. COMBUSTION AIR INLET WITH DUCTED INTAKE BOX

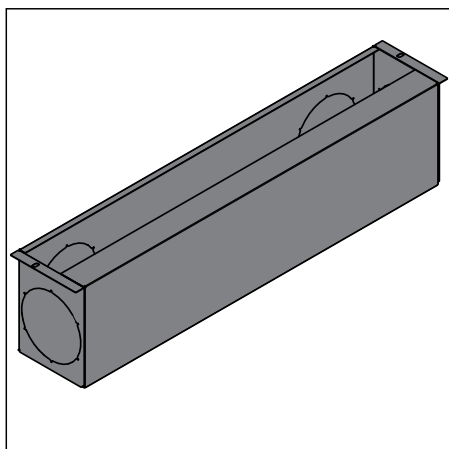

d. COMBUSTION AIR INTAKE BOX

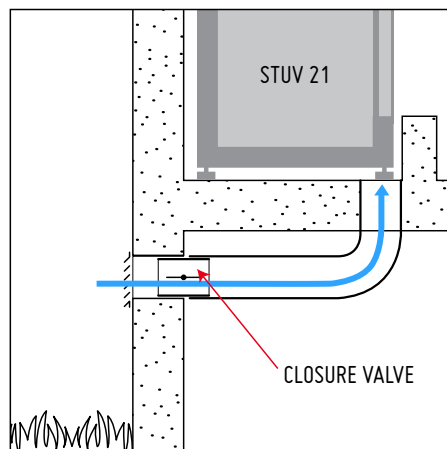

e. EXTERNAL COMBUSTION AIR INTAKE



f. EXTERNAL COMBUSTION AIR INTAKE

6. COMBUSTION

COMBUSTION AIR INLET

	INLET DIAMETER
STUV 21 / 95 SF	6 inches
STUV 21 / 105 SF	6 inches
STUV 21 / 125 SF	6 inches
STUV 21 / 135 SF	6 inches
STUV 21 / 95 DF	6 inches
STUV 21 / 125 DF	6 inches

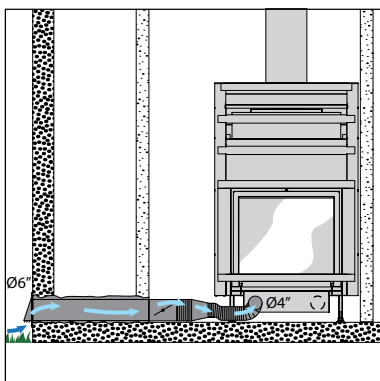

EXTERNAL COMBUSTION AIR (INTAKE BOX)

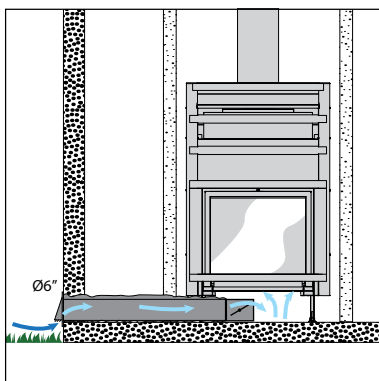

EXTERNAL COMBUSTION AIR (NO INTAKE BOX)

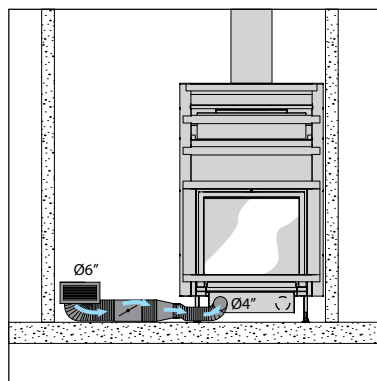

INTERNAL COMBUSTION AIR (INTAKE BOX)

7. TEST REPORT

TEST REPORT NO ASFT18044 (PRELIMINARY REPORT)

TESTING LABORATORY:	Australian Solid Fuel Testing
MANUFACTURER:	Stuv
MODEL:	Stuv 21
WORK REQUESTED:	Compliance with AS/NZS2918:2001 Standards
ISSUE DATE:	4/05/2018
INVESTIGATING OFFICER:	Steve Marland

CONCLUSION:

The Stuv 21 Inbuilt appliance installed with a triple skin flue system, conforms to the requirements of Australian/New Zealand Standard 2918:2001, with respect to floor, side wall and rear wall surface temperatures, when tested in the test position shown in p11, p14 and 15p of this report in accordance with Appendix B of AS/NZS2918;2001.

8. OPERATION

What you should burn

- Untreated, air dried hardwood
- Split logs with a humidity content of less than 20%

Do not burn

- Trash
- Painted plastic
- Coated or preservative treated wood
- Waste or black coal
- Inflammable liquids
- Fire gels
- Moist wood with a residual humidity content of more than 20% (this may cause sooting of the chimney).

WARNING:

- Do not use flammable liquids or aerosols to start or rekindle the fire.
- Do not use flammable liquids or aerosols in the vicinity of the fireplace when operating.
- Do not store fuel within prescribed installation clearance distances.
- The use of some types of preservative-treated woods as a fuel can be hazardous.
- Misuse may lead to unhealthy and environmentally harmful emissions and will void any warranty or guarantee.
- Burning only seasoned hardwood helps to protect the environment and lower emissions.